

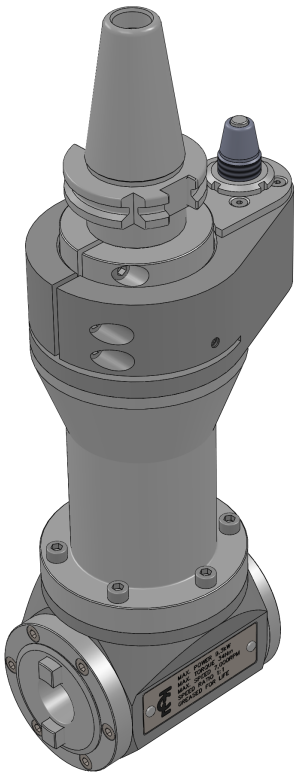





RAM160 - 280 Extended 90° Angle Head

160



Technical Data

	ISO20 Steep Taper Adaptor	
	Max. 7,000rpm Speed ratio 1 : 1	
	Max. @ 7,000rpm	9.3kW
	Max. @ 100rpm	34Nm
	(Without tools)	12.1kg
	Input Opposite to Output	

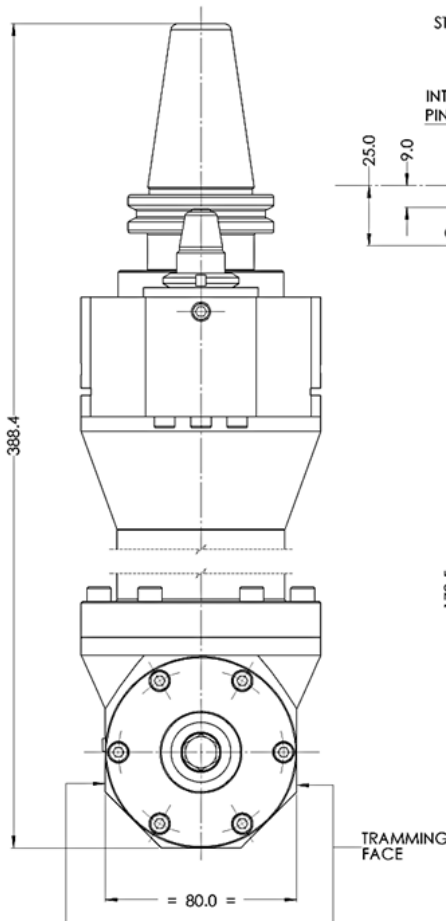
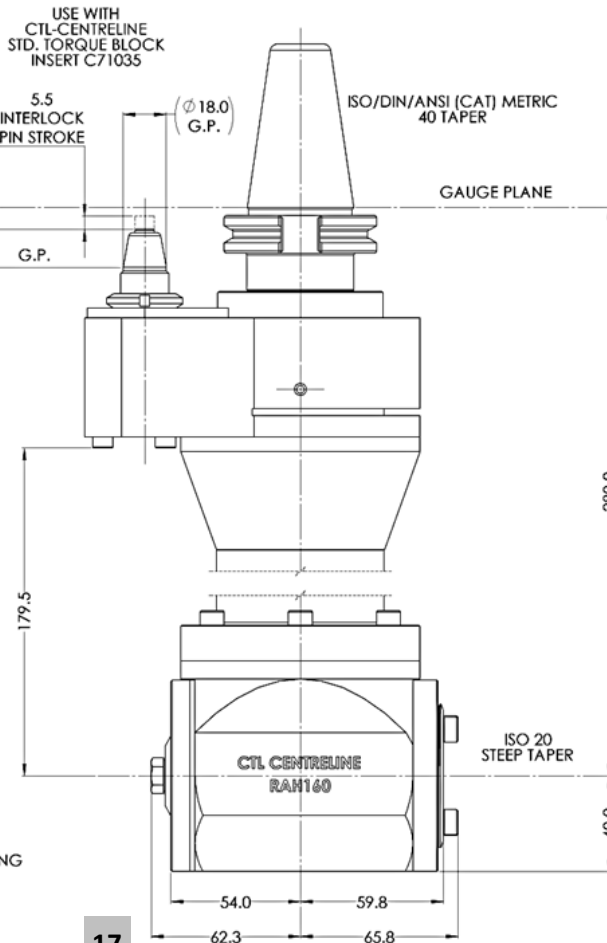
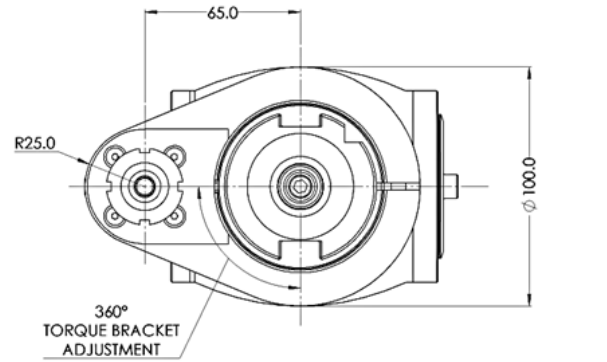
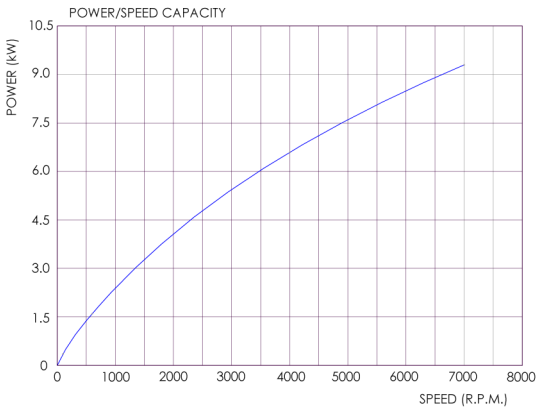

160 Series 90° Angle Heads

160

- Standard Length or Extended lengths available
- ER25 (16mm Cap.) Collet Chuck or Modular ISO20 Output as standard
- High Pressure Through Coolant option with Outlet via Body or Spindle
- Single or Double Output
- Location Pin Centres — 65mm (40ISO / HSK63), 80mm, 100mm & 110mm (50ISO)
- 360° adjustability
- Special output options available
- Maintenance free sealed design. Grease lubricated

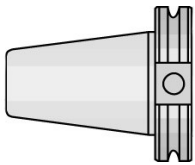

Available drive Tapers:

BT40—BT50

CAT40—CAT50 (DIN / ANSI / SK)

HSK63A, HSK80A, HSK100A

(Other options available on request)

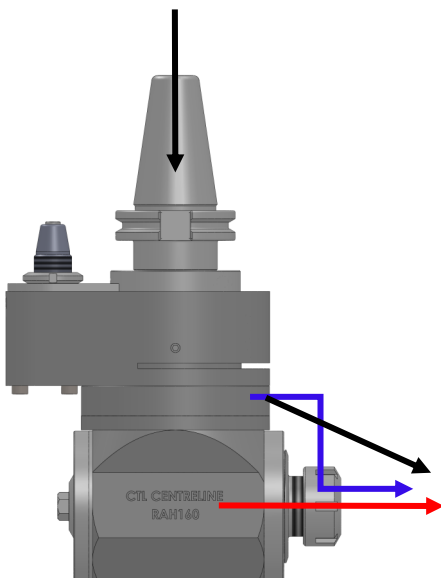

Internal Coolant Options:

A - In through Shank - Out through Body

B - In through Shank - Out through Spindle / Tool

C - In through Shank - out via Special Through Coolant Locknut