







SBH210 Set Back 90° Angle Head

210

Technical Data

	ER25A —16mm / M12
	Max. 7,000rpm Speed ratio 1 : 1
	Max. @ 7,000rpm 9.3kW
	Max. @ 100rpm 34Nm
	(Without tools) 9.8kg
	Input Opposite to Output

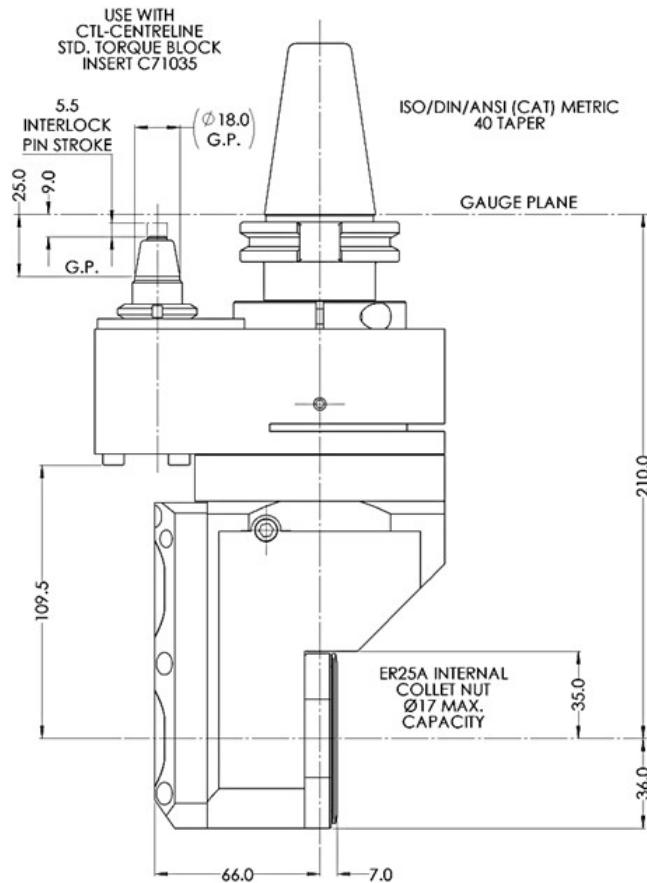
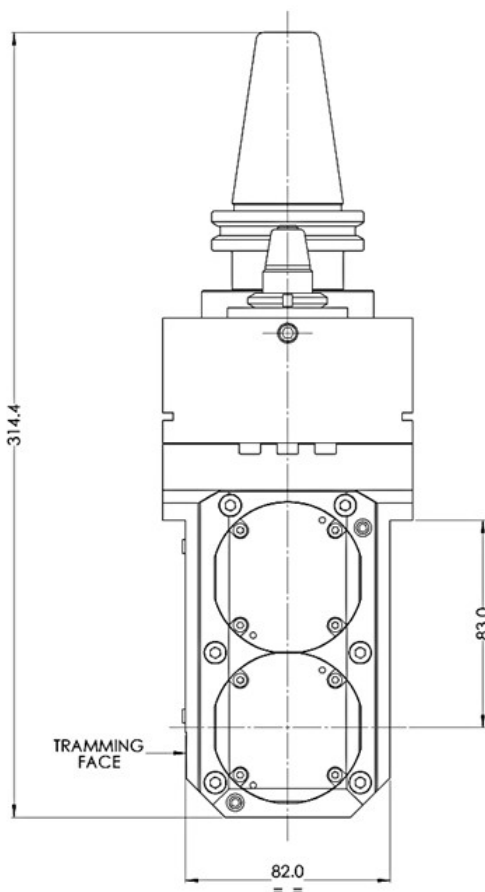
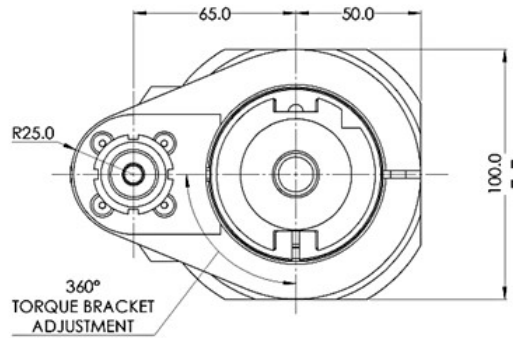
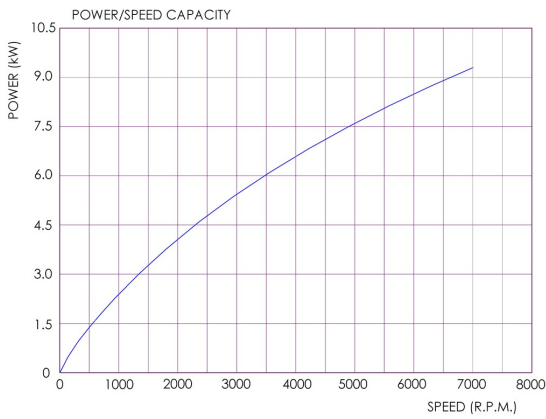

210 Series Set Back 90° Angle Heads

210

- Extended length available on request
- ER25 (16mm Cap.) Collet Chuck or dedicated milling arbor output options
- High Pressure Through Coolant option with Outlet via Body
- Location Pin Centres — 80mm, 100mm & 110mm
- 360° adjustability
- Special output options available
- Maintenance free sealed design. Grease lubricated

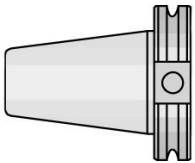

Available drive Tapers:

BT40 - BT50

CAT40 - CAT50 (DIN / ANSI / SK)

HSK63A, HSK 80A, HSK 100A

(Other options available on request)

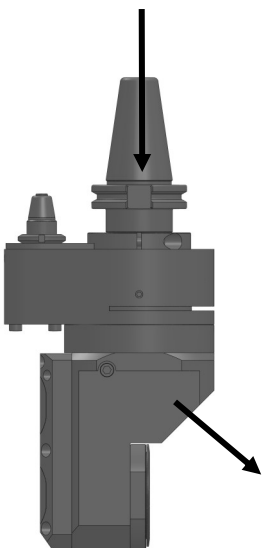

Internal Coolant Options:

A - In through Shank - Out through Body